



VHR5-2800D SERIES

HIGH RELIABILITY COTS DC-DC CONVERTERS

Models Available

Input: 15 V to 50 V continuous, 80 V transient
 5 W, dual outputs of 5 V, 12 V, 15 V
 -40 °C to 100 °C Operation

DATASHEET

1.0 DESCRIPTION

The VHR series of industrial grade DC-DC converters provides cost effective, high reliability solutions for use in defense, avionics and manufacturing industries. The VHR industrial grade products leverage decades of VPT's proven heritage in military and aerospace electronics.

VPT's VHR5-2800D series is ideal for non flight-critical solutions in military, avionics, unmanned systems as well as manufacturing equipment and controls. A wide input voltage range which accommodates nominal 28 V inputs, low input and output ripple, fixed operating frequency and companion EMI filters simplify system design while ensuring operating success in the most rugged of environments.

These converters are designed and manufactured in a facility certified to ISO9001, J-STD-001 and IPC-A-610.

This product may incorporate one or more of the following U.S. patents:

- 5,784,266
- 5,790,389
- 5,963,438
- 5,999,433
- 6,005,780
- 6,084,792
- 6,118,673



1.1 FEATURES

- High Reliability at Low Cost
- 5 Watts Output Power
- Wide Input Voltage Range: 15 to 50 Volts per MIL-STD-704 and MIL-STD-1275
- High Input Transient Voltage: 80 Volts for 1 sec per MIL-STD-704A
- Input Undervoltage Lockout
- Fixed Frequency
- Output Soft Start
- Current Limit Protection
- Short Circuit Protection
- Magnetic Feedback, no Optoisolators
- Wide Temperature Range, -40 °C to 100 °C
- Internally Conformal Coated
- Standard Six Sided Non-Hermetic Rugged Metal Package

1.2 COMPLIANCE

- MIL-STD-1275
- MIL-STD-704
- Meets MIL-STD-461D-F and EN55022 when used with an appropriate VHR EMI Filter

1.3 PACKAGING

- Low-profile: 1.110" x 1.110" x 0.400"
- Max weight: 24 g

1.4 SIMILAR PRODUCTS AND ACCESSORIES

- [DVSA](#) 5 W dual output DC-DC Converter
- [VPT5](#) 5 W dual output COTS DC-DC Converter
- [EMI filters, Thermal Pads, Front-End Modules and Accessories](#)

2.0 DESCRIPTION

2.1 BLOCK DIAGRAM

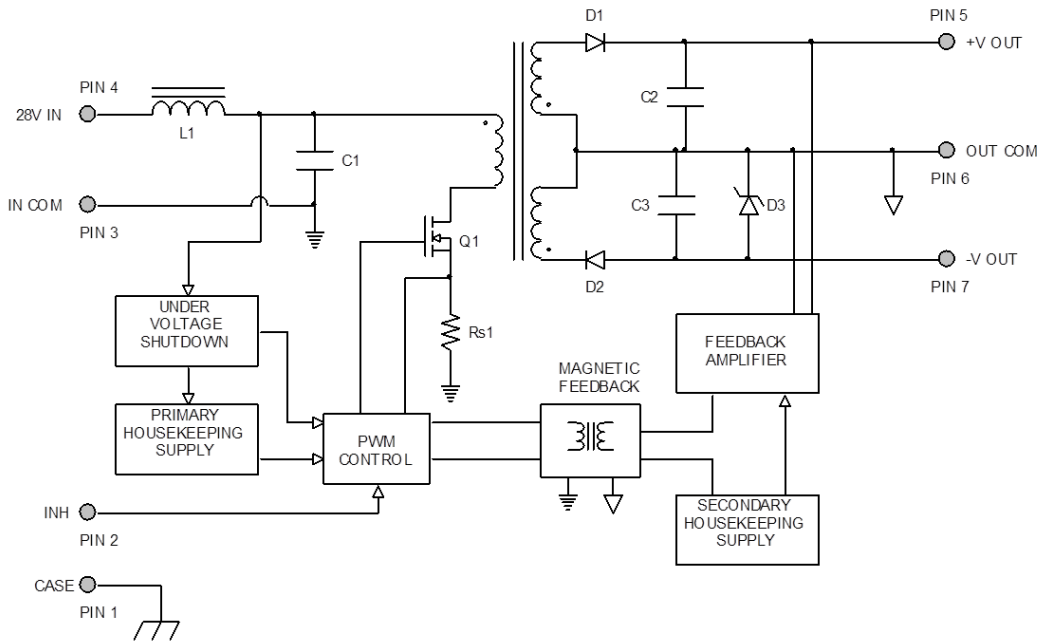

2.2 CONNECTION DIAGRAM

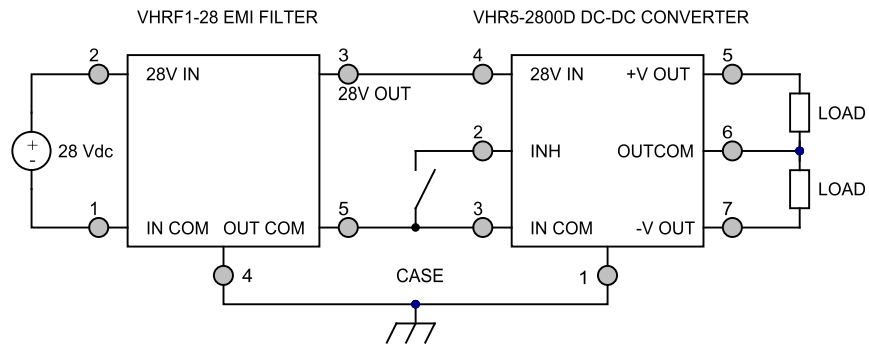

2.2 CONNECTION DIAGRAM (CONTINUED)

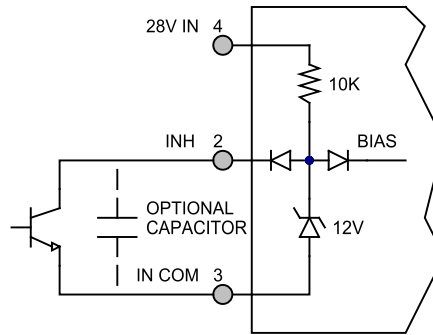

Inhibit Circuit (Shown with optional capacitor for turn-on delay)

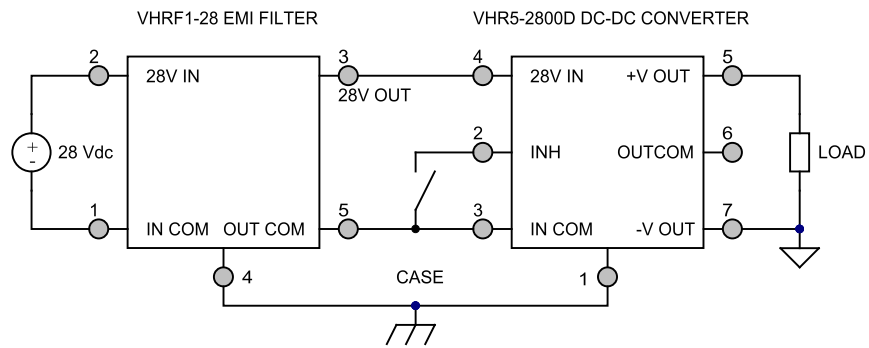

Stacked Output Connection (Shown with optional EMI filter)

3.0 SPECIFICATIONS

3.1 ABSOLUTE MAXIMUM RATINGS

Absolute Maximum Ratings

Input Voltage (Continuous):	50 V	Operating Temperature (Full Load):	-40 °C to 100 °C
Input Voltage (Transient, 1 second):	80 V	Storage Temperature:	-55 °C to 125 °C
		Lead Solder Temperature (10 seconds):	300 °C

3.2 PERFORMANCE SPECIFICATIONS

Tcase = -40 °C to 100 °C, Vin = +28 V ± 5%, Full Load⁴, Unless Otherwise Specified

Parameter	Conditions	VHR5-2805D			VHR5-2812D			Units
		Min	Typ	Max	Min	Typ	Max	
INPUT								
Voltage	Continuous	15	28	50	15	28	50	V
	Transient, 1 sec ³	-	-	80	-	-	80	V
Current	INH < 1.5 V	-	4	6	-	4	6	mA
	No Load	-	40	60	-	40	60	mA
Ripple Current	20 Hz to 10 MHz	-	30	50	-	30	50	mApp
Undervoltage Lockout	Turn On	12	-	14.8	12	-	14.8	V
	Turn Off ³	11	-	14.5	11	-	14.5	V
OUTPUT STATIC								
Voltage	+Vout, Tcase = 25 °C	4.92	5	5.08	11.7	12	12.3	V
	+Vout, Tcase = -40 °C to 100 °C	4.87	5	5.13	11.58	12	12.42	V
	-Vout, Tcase = 25 °C	4.87	5	5.13	11.7	12	12.3	V
	-Vout, Tcase = -40 °C to 100 °C	4.82	5	5.18	11.58	12	12.42	V
Power ^{2,5}	Total	0	-	5	0	-	5	W
	Either Output	0	-	3.5	0	-	3.5	W
Current ^{2,5}	Either Output	0	-	0.7	0	-	0.29	A
Ripple Voltage	20 Hz to 10 MHz	-	35	75	-	20	50	mVpp
Line Regulation	+Vout, Vin = 15 V to 50 V	-	1	10	-	1	10	mV
	-Vout, Vin = 15 V to 50 V	-	5	50	-	30	150	mV
Load Regulation ⁶	+Vout, No Load to Full Load	-	1	15	-	1	25	mV
	-Vout, No Load to Full Load	-	20	100	-	55	200	mV
Cross Regulation, -Vout	+Vout: 70% load, -Vout: 30% load	-	150	300	-	200	300	mV
	+Vout: 30% load, -Vout: 70% load	-	-	-	-	-	-	mV
Load Fault Power Dissipation	Overload ³	-	-	5	-	-	5	W
OUTPUT DYNAMIC								
Load Step, Half to Full Load	Output Transient	-	65	150	-	100	200	mVpk
	Recovery ¹	-	150	300	-	200	500	µs
Line Step ³ , Vin = 16 V to 40 V	Output Transient	-	20	50	-	55	120	mVpk
Turn On, Vin = 0 to 28 V	Delay	-	10	20	-	10	20	ms
	Overshoot	-	0	25	-	0	50	mVpk
FUNCTION								
INH Pin Input ³	Output Inhibited	0	-	1.5	0	-	1.5	V
INH Pin Open Circuit Voltage ³	Output Enabled	9	11	13	9	11	13	V
GENERAL								
Efficiency		67	73	-	69	74	-	%
Capacitive Load ³	Either Output	-	-	300	-	-	100	µF
Switching Frequency		425	500	550	425	500	550	kHz
Isolation	500 VDC, Tcase = 25 °C	100	-	-	100	-	-	MΩ
Weight		-	-	24	-	-	24	g
MTBF (MIL-HDBK-217F)	GM @ Tcase = 55 °C	-	363	-	-	363	-	kHr

1. Time for output voltage to settle within 1% of its nominal value
2. Derate linearly to 0 at 110 °C
3. Verified by qualification testing
4. Half load at +VOUT and half load at -VOUT
5. Up to 70% of the total power or current can be drawn from either of the two outputs
6. 5% Load to Full Load at -40 °C

3.2 PERFORMANCE SPECIFICATIONS (CONTINUED)

Tcase = -40 °C to 100 °C, Vin = +28 V ± 5%, Full Load⁴, Unless Otherwise Specified

		VHR5-2815D			
Parameter	Conditions	Min	Typ	Max	Units
INPUT					
Voltage	Continuous	15	28	50	V
	Transient, 1 sec ³	-	-	80	V
Current	INH < 1.5 V	-	4	6	mA
	No Load	-	40	60	mA
Ripple Current	20 Hz to 10 MHz	-	30	50	mApp
Undervoltage Lockout	Turn On	12	-	14.8	V
	Turn Off ³	11	-	14.5	V
OUTPUT STATIC					
Voltage	+Vout, Tcase = 25 °C	14.62	15	15.38	V
	+Vout, Tcase = -40 °C to 100 °C	14.47	15	15.53	V
	-Vout, Tcase = 25 °C	14.62	15	15.38	V
	-Vout, Tcase = -40 °C to 100 °C	14.47	15	15.53	V
Power ^{2,5}	Total	0	-	5	W
	Either Output	0	-	3.5	W
Current ^{2,5}	Either Output	0	-	0.23	A
Ripple Voltage	20 Hz to 10 MHz	-	20	50	mVpp
Line Regulation	+Vout, Vin = 15 V to 50 V	-	1	10	mV
	-Vout, Vin = 15 V to 50 V	-	30	150	mV
Load Regulation ⁶	+Vout, No Load to Full Load	-	1	25	mV
	-Vout, No Load to Full Load	-	55	200	mV
Cross Regulation, -Vout	+Vout: 70% load, -Vout: 30% load	-	200	300	mV
	+Vout: 30% load, -Vout: 70% load	-	-	-	-
Load Fault Power Dissipation	Overload ³	-	-	5	W
OUTPUT DYNAMIC					
Load Step, Half to Full Load	Output Transient	-	100	200	mVpk
	Recovery ¹	-	200	500	µs
Line Step ³ , Vin = 16 V to 40 V	Output Transient	-	55	150	mVpk
Turn On, Vin = 0 to 28 V	Delay	-	10	20	ms
	Overshoot	-	0	50	mVpk
FUNCTION					
INH Pin Input ³	Output Inhibited	0	-	1.5	V
INH Pin Open Circuit Voltage ³	Output Enabled	9	11	13	V
GENERAL					
Efficiency		70	75	-	%
Capacitive Load ³	Either Output	-	-	100	µF
Switching Frequency		425	500	550	kHz
Isolation	500 VDC, Tcase = 25 °C	100	-	-	MΩ
Weight		-	-	24	g
MTBF (MIL-HDBK-217F)	GM @ Tcase = 55 °C	-	363	-	kHr

1. Time for output voltage to settle within 1% of its nominal value
2. Derate linearly to 0 at 110 °C
3. Verified by qualification testing
4. Half load at +VOUT and half load at -VOUT
5. Up to 70% of the total power or current can be drawn from either of the two outputs
6. 5% Load to Full Load at -40 °C

4.0 PERFORMANCE CURVES

T_{case} = 25 °C, Full Load, Unless Otherwise Specified

4.1 EFFICIENCY PERFORMANCE CURVES

4.1.1 VHR5-2805D Efficiency (%) vs. Output Power (W)

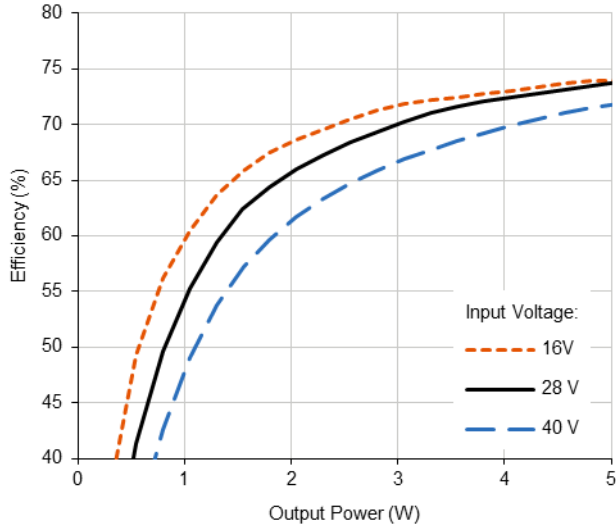

4.1.2 VHR5-2812D Efficiency (%) vs. Output Power (W)

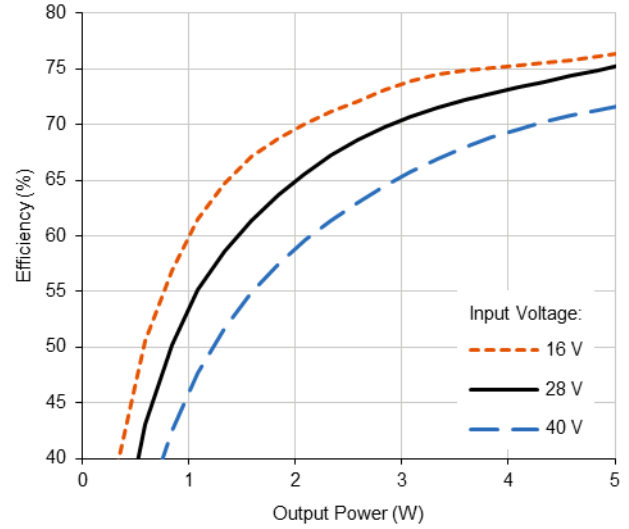

4.1.3 VHR5-2815D Efficiency (%) vs. Output Power (W)

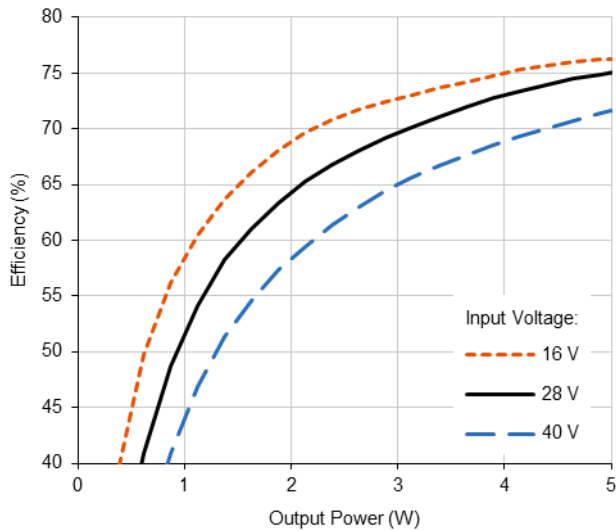

4.0 PERFORMANCE CURVES (CONTINUED)

4.2 CROSS REGULATION CURVES

4.2.1 VHR5-2805D -Vout (V) vs. -Iout (A)

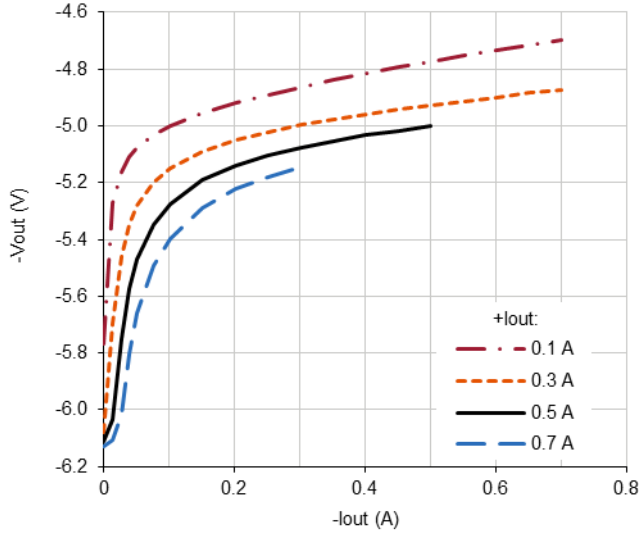

4.2.2 VHR5-2812D -Vout (V) vs. -Iout (A)

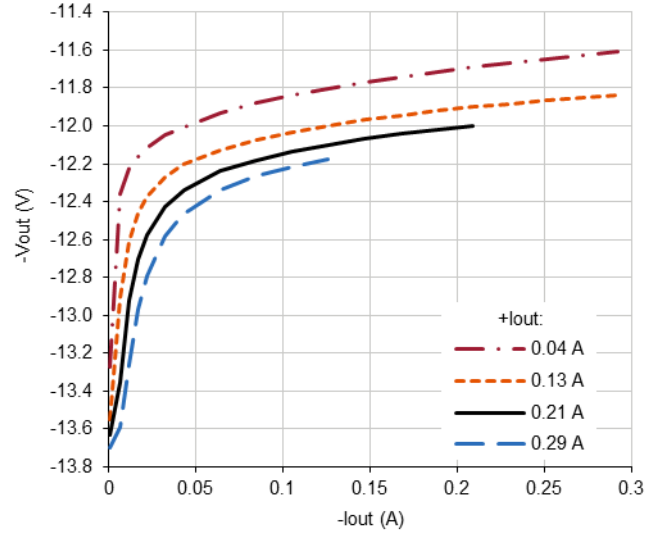

4.2.3 VHR5-2815D -Vout (V) vs. -Iout (A)

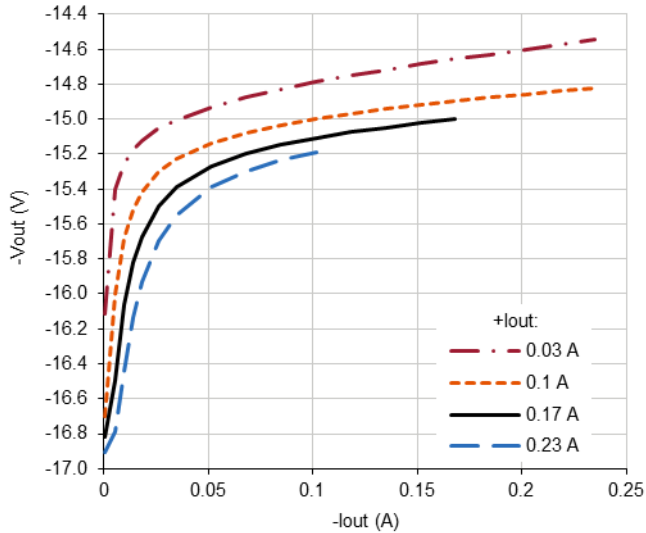

5.0 MECHANICAL OUTLINES AND PINOUT

Standard Package:

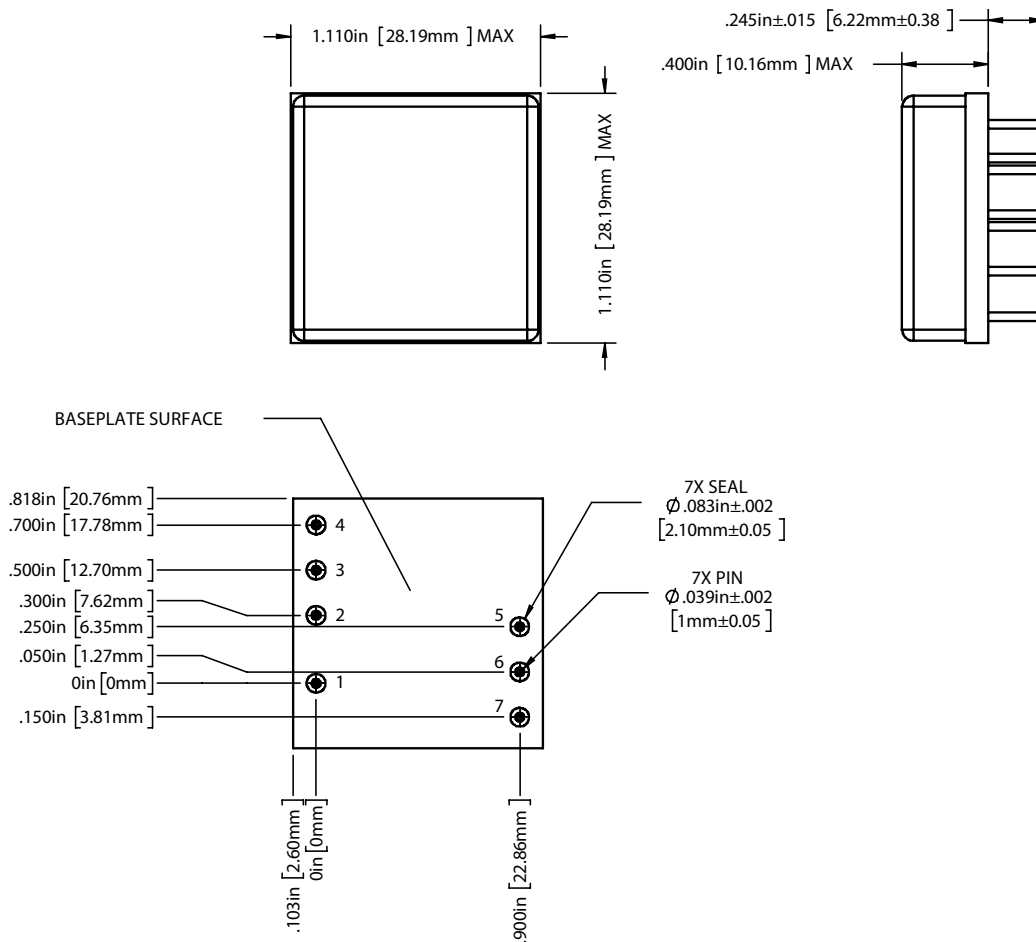

1. Case temperature is measured on the center of the baseplate surface.
2. Materials: Baseplate (Aluminum, conductive conversion coating); Cover (Nickel Plated); Pins (Copper, gold over nickel plating)
3. This Package is not hermetic. VPT offers a wide range of hermetic products. Please contact VPT for details if hermetic products are required.
4. For applications requiring exposure to liquid cleaning, please contact VPT.

Pin	Function	Pin	Function
1	CASE	5	+VOUT
2	INHIBIT	6	OUTCOM
3	INCOM	7	-VOUT
4	28VIN		



6.0 PACKAGE PIN DESCRIPTION

Pin	Function	Description
1	CASE	Case Connection.
2	INHIBIT	This is an open collector input. Logic Low = Disabled Output. Connect the inhibit pin to input common to disable the output. Unconnected, open collector or open drain = Enabled Output.
3	INCOM	Input Return Connection.
4	28VIN	Positive Input Voltage Connection.
5	+VOUT	Positive Output Voltage Connection.
6	OUTCOM	Output Return Connection.
7	-VOUT	Negative Output Voltage Connection.

7.0 ENVIRONMENTAL SCREENING

Screening	Condition
Internal Visual	IPC-A-610, Class 3
Final Electrical	100% at 25 °C
External Visual	Internal Procedure

8.0 ORDERING INFORMATION

VHR5-	28	05	D
1	2	3	4

(1) Product Series	(2) Nominal Input Voltage	(3) Output Voltage	(4) Number of Outputs
VHR5-	28	28 Volts	Dual
		05 ±5 Volts	
		12 ±12 Volts	
		15 ±15 Volts	

Please contact your sales representative or the VPT Inc. Sales Department for more information concerning additional environmental screening and testing, different input voltage, output voltage, power requirements, and source inspection.

9.0 CONTACT INFORMATION

To request a quotation or place orders please contact your sales representative or the VPT, Inc. Sales Department at:

Phone: (425) 353-3010
 Fax: (425) 353-4030
 E-mail: vptsales@vptpower.com

All information contained in this datasheet is believed to be accurate, however, no responsibility is assumed for possible errors or omissions. The products or specifications contained herein are subject to change without notice. VPT, its logo and tagline are registered trademarks in the U.S. Patent and Trademark Office.

10.0 ADDITIONAL INFORMATION

Visit the [VPT website](http://www.vptpower.com) for additional technical resources, including:

[Product Literature](#)



[Application Notes and White Papers](#)

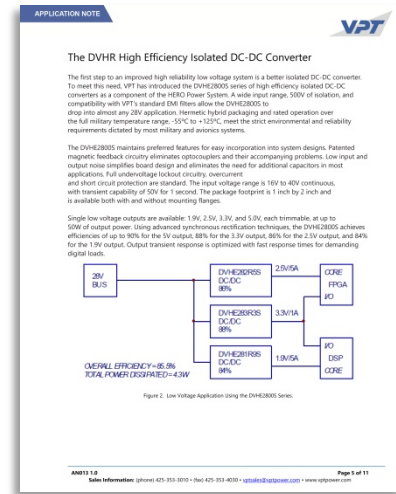

[Technical Video Labs](#)



[Additional Products For Avionics/Military, Hi-Temp, Hi-Rel COTS, and Space Applications](#)

